



United Music Corp.  
Chicago

## United Music Corp. of Chicago

- Manufacturer of the **United** Coin-Op Phonographs -

The United Manufacturing Co. was founded in 1942 by two men, who came from Exhibit Supply Co. in Chicago. Harry Edward Williams, who had been active as innovator and developer of gaming machines since 1934 was a well educated engineer from Stanford University, Los Angeles, and during the working hours at Exhibit Supply Co. at 4222-30 West Lake Street he met the mechanical genius Lyndon Alfred Durant, who had been a radio salesman in his younger years in Springfield, Massachusetts. Harry E. Williams became rather impressed by Lyndon A. Durant's designs for gaming apparatus, and when the time was right they both left Exhibit Supply Co., and established their own manufacturing facilities at 6123-25 North Western Avenue in Chicago to refurbish old games and to obtain wartime manufacturing contracts. The main activity was reconditioning of older machines to be installed in military recreation centers, but also new machines like pin-balls and shuffle-alleys were developed and produced for the coin-op market.

**Games that get the play**

STREAMLINER . . . . .	Converted from STARS
GRAND CANYON . . . . .	Converted from DOUBLE PLAY
SANTA FE . . . . .	Converted from WEST WIND
BRAZIL . . . . .	Converted from BO - E.C. - ME
ARIZONA . . . . .	Converted from SUN BEAMS
MIDWAY . . . . .	Converted from ZOMBIE

SEE YOUR DISTRIBUTOR NOW OR WRITE DIRECT

**United MANUFACTURING COMPANY**  
6123-25 N. WESTERN AVENUE CHICAGO

After two years the partners split up, and Harry E. Williams founded his own Williams Manufacturing Co. in 1944, later to be known as one of the finest pinball manufacturers worldwide, and Harry E. Williams became known as the *Father of Pinball*. Lyndon A. Durant continued manufacturing electromechanical gaming machines for many years at 3401 North California Avenue and 5737 North Broadway, a new plant from 1948, and more than a decade later the United Music Corp. was established as an affiliation to produce modern style music machines from 1957 until 1961. The jukeboxes were, however, not a great success as it was said on the market that they were almost unrivalled in the capacity to radiate absolutely nothing, which meant that they did not have the expected eye and play appeal. Today it must be said that United Music Corp. came up with the most remarkable jukebox series of the *Silver Age* of coin-op phonographs. The first two models, the *UPA-100* and *UPB-100*, and the carousel mechanism and also the design for the *Ultra Compact Wall-Box* resulted in five design patents filed by Lyndon Alfred Durant. Also the trademark U.M.C. with musical notes was filed for registration on the 19th December 1957. The name of the famed designer Raymond Loewy is often connected to the

design of the United jukebox series, and most likely his Design Studio in New York was consulted, but the designer name on the patents will always be Lyndon A. Durant.



The industrial design legend Raymond Loewy (1893-1986) was one of the architects of the *American Streamline Movement*, and his style surely influenced the design of the United phonograph series. The models, *UPA-100*, *UPB-100*, *UPC-100*, and *UPD-100* produced from 1957 until 1961. Raymond Loewy's daughter Laurence Loewy (1953-2008) stated several times that her father mentioned the United jukebox as one of his own favourite designs. This was not the first time the Raymond Loewy Studio in New York was consulted concerning jukebox cabinet design.



Raymond Loewy's studio apartment at 900 5th Avenue in New York (1960)

In 1962 Lyndon A. Durant ran into serious problems as the government accused him of income tax evasion in the period from 1954 until 1956, the same period the music

department was getting ready for jukebox production, and he was late in 1962 sentenced to sixty days in jail and was fined \$15K. The lawyer George Crowley asked, but without success, that Durant should be placed on probation, and not be jailed, as the United Manufacturing Co. was involved in a large 8.5 million dollar government contract, and Lyndon A. Durant was needed to supervise the project. At the time Lyndon A. Durant was living in a penthouse apartment on top of the United factory building at North California Avenue. Soon after Durant lost his appeal at the U.S. Court of Appeals in November 1963 the mighty Seeburg Corp. became seriously interested in taking over part of the United Manufacturing Co.. This was in fact only a continuation of Seeburg's strategy and six year acquisition program launched in 1958. In June 1964 Seeburg Corp. took over Williams Electronic Mfg. Corp. now headed by one of the grand old men in the coin-op industry, Sam Stern, who bought out Harry E. Williams in 1951. Seeburg's main interest in the United Manufacturing Co. in September 1964 was the game assets including finished products, patent rights and pending applications, equipment and machinery related to the amusement machine business, and the main plant on 3401 North California Avenue. Interesting was that patents, tools, and dies related to the no longer active jukebox production, and the facility on 5737 North Broadway were not included in the deal; - in short the United Music Corp. affiliation. With the United deal it seems Seeburg Corp. had reached its goal, and the vice-president in charge of sales and marketing, William (*Bill*) Francis Adair, stated that Seeburg with the latest Williams and United deals was now able to provide operators with a complete game line as well as complete lines in music and vending. Sam Stern now headed both the Williams and the United subsidiaries of the Seeburg Corp..



Harry Edward Williams  
1906 - 1983



Sidney (*Sam*) Stern  
1907 - 1984



William (*Bill*) F. Adair  
1919 - 2004

Finally, concerning the United Manufacturing Co. in the fifties it can be mentioned that Lyndon A. Durant was involved in thermal electronics research by partly funding the inventor and pioneer in electronics Lee De Forest's experiments in his Californian laboratory from 1950 until 1958. Lee De Forest (1873-1961) was presented with the Edison Medal (1946) by the Institute of Electrical and Electronics Engineers for a

career of meritorious achievement in electrical science, electrical engineering, or the electrical arts. The second in command at United, when Durant was on one of his many travels to either Hawaii or California, was vice-president Herbert (*Herb*) Livingston Oettinger (1908-1991), a former auditor at Mills Novelty Co., and other leading officers of the company for more than a decade were Raymond (*Ray*) James Riehl (1899-1984) and general sales manager Charles (*Billy*) Bernard DeSelm (1907-1985). All three managers stayed at United after Sam Stern took over.



Ray Riehl and Herb Oettinger  
(1950)



Billy DeSelm  
(1954)

However, not much is known about the last years of Lyndon A. Durant's life in the latter half of the sixties, and he died much too young aged 60 suffering a heart attack on the 29th January 1969. He was born on the 20th May 1908 in Plattsburg, New York. His parents were Alfred Albert Durant and Mildred Agnes Bouche. Lyndon was married to Katherine Marie Kumor (1913-2001) in June 1941, and they sadly lost a baby girl in March 1946. A son Lyndon Alfred Durant Jr. was born 1954 in Los Angeles, but sadly also he died much too young in 1982 in Hawaii. Lyndon A. Durant later lived with Nola Lee Cargill (1930-1981), but it has not been confirmed they were married when he died in 1969. [Further genealogical research needed.](#)



Lyndon (*Lyn*) A. Durant  
(1946)

The other founder of United Manufacturing Co. in 1942, Harry E. Williams, was born *Henry* Edward on the 3rd June 1906 in Bronx, New York, His parents were Mervin Clark Williams and Eliza Lang. Harry was married to Jean Elnora Thurman (1908-1983) in Los Angeles in October 1929, and Harry married his second wife Leona

Elizabeth Irving (1919-1971) in Chicago in June 1941. Further genealogical research needed. Harry Edward Williams died aged 77 in Palm Springs, California, on the 11th September 1983 after the last battle on the playfield against cancer. His active life in the coin-op and pinball business is well documented in a transcript of an interview early in 1978 published by Russ Jensen.

The two founders of the United Manufacturing Co. in 1942 really deserve their places in the Amusement Industry Hall of Fame.

--- 0 ---

*Gert Almind, Nov-2010*

*Revised, Feb-2024*



Phonograph equipment manufactured by United Music Corp.

Prod.	Description	Sel.
UPA-100	Phonograph	100
UPB-100	Phonograph	100
UPB-100S	Stereo Phonograph	100
UPB-100H	Hide-Away Phonograph	100
UPC-100	Phonograph	100
UPC-100H	Hide-Away Phonograph	100
UPD-100	Phonograph	100
UWB-1	Selective 3-Wire Wall Box for UPB and UPC	
UWB-2	Selective 3-Wire Wall Box for UPD	
UBG-1	Bar Grip	
UAP-1	Aux. Power Supply for Extra Wallboxes	
UCS-1	8 Inch Dual Cone Corner Speaker	
UWS-1	8 Inch Dual Cone Wall Speaker	
UWS-1	8 Inch Dual Cone Recessed Ceiling Speaker	
UCS-2	12 Inch Dual Cone Corner Speaker for Stereo	
UWS-2	12 Inch Dual Cone Wall Speaker for Stereo	
URV-1	Remote Volume Control and Cancel for Monaural	
URV-2	Remote Volume Control and Cancel for Stereo	
URA-1	Remote Amplifier for Increased Audio Power	
UMS-1	Microphone System for Paging or Public Address	
UPS-1	Play Stimulator for UPB-100 Series	

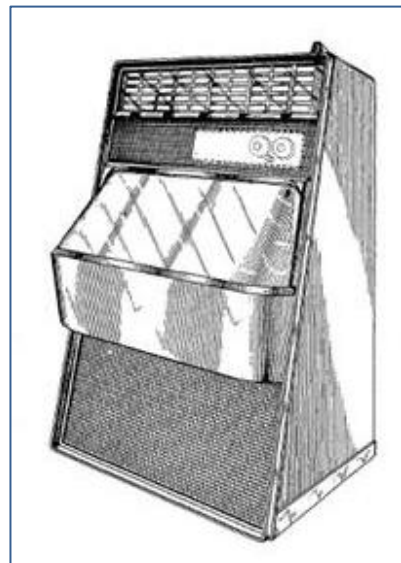
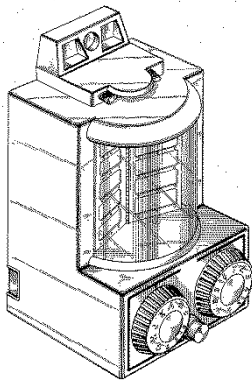
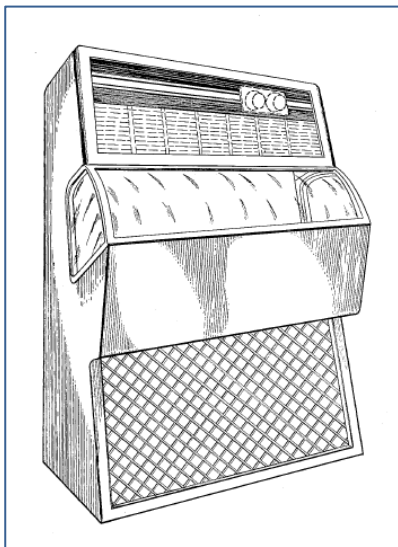

Patents, designs, and trademark registered for United Music Corp.

No.	Description	Filed	Granted
D181,043	Casing for phonograph	02/14 1957	09/24 1957
D183,602	Phonograph remote control unit	07/10 1957	09/30 1958
D183,792	Multi-selector phonograph control	02/26 1957	10/28 1958
D187,343	Combined turntable and magazine unit for a phonograph	08/12 1958	03/01 1960
D188,813	Phonograph cabinet	06/16 1958	09/13 1960
675,003	Trademark, U.M.C. AND DESIGN	12/19 1957	12/16 1958
2,866,865	Multi-selector	04/10 1957	12/30 1958
2,903,622	Popularity meter for phonograph record playing apparatuses	09/07 1954	03/29 1960
2,909,373	Record magazine and drive therefor	04/10 1957	10/20 1959
2,922,575	Electric credit accumulator	02/14 1957	01/26 1960
2,935,325	Record transfer mechanism	06/19 1957	05/03 1960
3,028,160	Automatic rejector for phonographs	08/12 1958	04/03 1962
3,028,580	Record player and selecting system therefor	04/07 1958	04/03 1962
3,162,778	Electric thermal generator	07/03 1961	12/22 1964

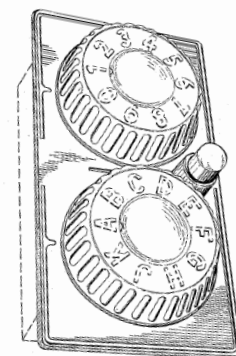
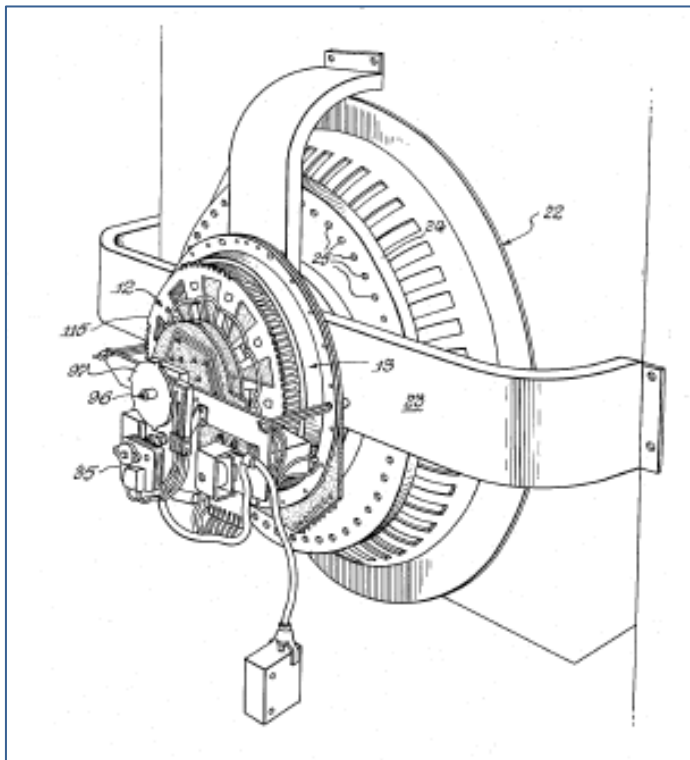



Feb. 4, 1941.

L. A. DURANT

2,230,486

SELECTOR MECHANISM

Filed June 15, 1939

2 Sheets—Sheet 1

Fig. 1.

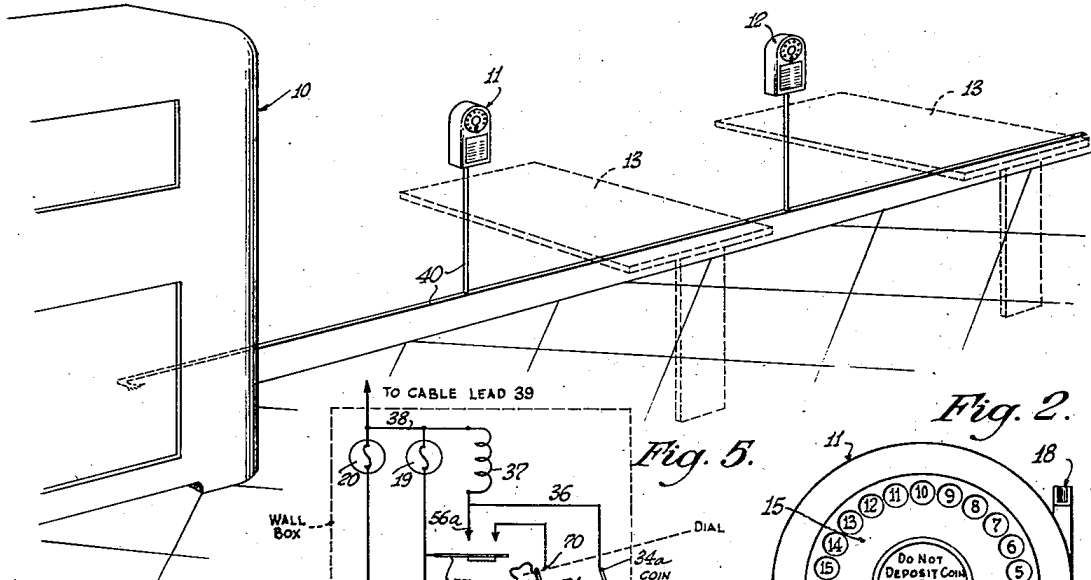

Fig. 3.

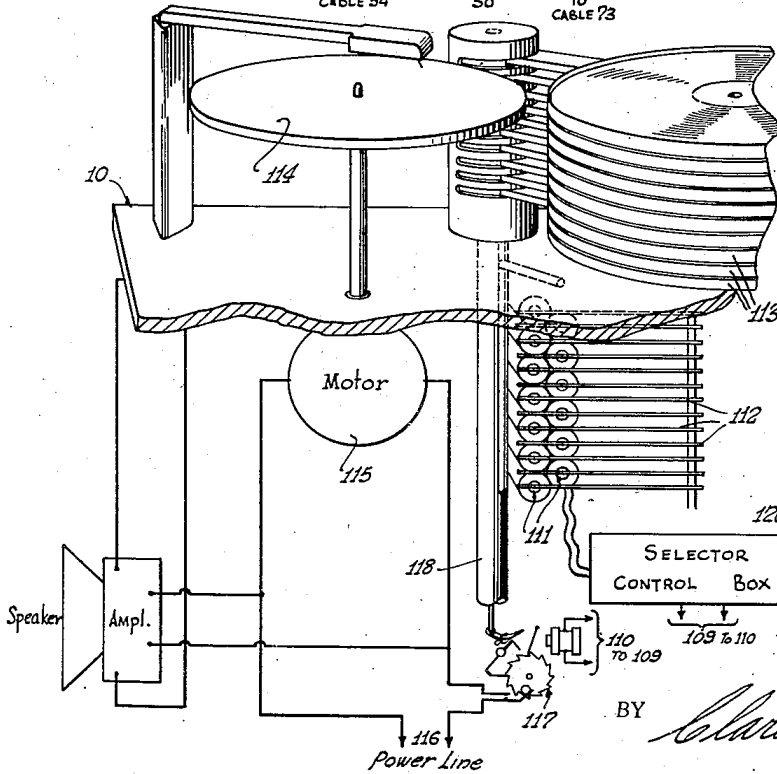

Fig. 5.

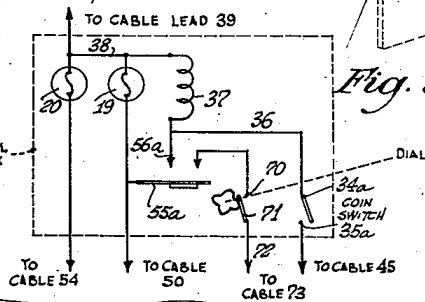
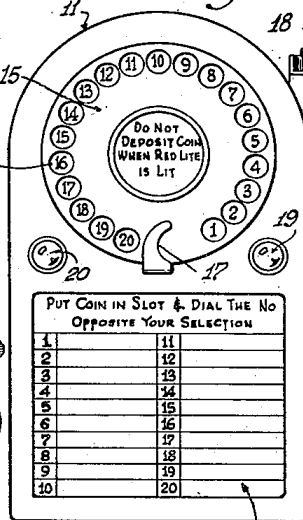

Fig. 2.



Lyndon A. Durant  
INVENTOR.

BY *Clarence E. Freedy*  
HIS ATTORNEY.